



Sigma Mini Servo System Product Catalog Supplement

SGMM Sigma Mini Servo System

SGMM Ratings & Specifications.....	5 - 6
SGMM Speed/Torque Curves.....	7
SGMM Dimensions.....	8 - 9
SGMM Selection/Ordering Information.....	10 - 14

SGDF Sigma Mini Servo Amplifier

SGDF Ratings & Specifications.....	15 - 17
SGDF Dimensions.....	18
SGDF Internal Connection Diagrams.....	19 - 22
Overload Characteristics.....	23
Cable Specifications and Peripheral Devices.....	24 - 26

NOTES:

Super High Power Rate Series

SGMM Servomotors - With Incremental Encoder

Rated Output: 10W, 20W



For Additional Information	Page(s)
SGMM Ratings & Specifications	6
SGMM Speed/Torque Curves	7
SGMM Dimensions	8 - 9
SGMM Selection/Ordering Information	10 - 14
SGDF Ratings & Specifications	15 - 17

Design Features

1. Compact

- Small sized motor
 - Two frame sizes: up to 27.1oz-in. peak torque.
 - Smaller installation space for more compact machine designs.
 - High torque to inertia ratio.

2. High Speed and Power

- High power rating
 - High power is achieved by minimizing the inertia of the motor.
 - This increases the acceleration/deceleration rate and reduces positioning time.
- Maximum rotation speed of 5000rpm
 - Increases maximum rotation speed and shortens positioning time.
- Rated speed of 3000rpm

3. Encoder

- 2048 PPR incremental encoder (standard)

4. Enclosure

- Totally enclosed, self-cooled IP55 (not including shaft).
- Vibration resistance: 5G.

5. Application Emphasis

- Semiconductor equipment
- Chip mounters
- Robots
- Packaging

6. Certified International Standards

- CE compliance.

Servomotor Ratings and Specifications

Time Rating: Continuous

Insulation: Class B

Vibration: 15µm or less

Withstand Voltage: 1000VAC

Insulation Resistance: 500VDC

10MΩ minimum

Enclosure: Totally-enclosed, self-cooled

Ambient Temperature: 0 to 40°C

Ambient Humidity: 20 to 80%
(non-condensing)

Rated Rotation Speed: 3000rpm

Max. Rotation Speed: 5000rpm

Excitation: Permanent magnet

Drive Method: Direct drive

Mounting: Flange-mounted

Applicable Encoder:

Incremental encoder 2048PPR

SGMM

Applied Voltage	MOTOR: SGMM-	Rate Output W (hp)	Rated Torque oz · in (N · m)	Instantaneous Peak Torque oz · in (N · m)	Continuous Rated Current* A _{rms}	Maximum Peak Current* A _{rms}	Rated Angular Acceleration rad/s ²	Rated Power Rating KW/s
24VDC	A1□	10 (0.013)	4.5 (0.0318)	13.5 (0.0955)	2.1	6.0	90000	2.9
	A2□	20 (0.027)	9.02 (0.0637)	27.1 (0.191)	2.0	5.7	120000	7.4

*Values when servomotor is combined with SGDF servo amplifier.

Applied Voltage	MOTOR SGMM-	Moment of Inertia (J _M)		Holding Brake (at 20°C)				Allowable Load Inertia (J _L)
		Motor without Brake	Motor with Brake	Capacity	Torque	Coil Resistance	Rated Current	
		oz · in · s ² × 10 ⁻³ (kg _f · m ² × 10 ⁻⁴)	oz · in · s ² × 10 ⁻³ (kg _f · m ² × 10 ⁻⁴)	W	kg _f · m	Ω	A	oz · in · s ² × 10 ⁻³ (kg · m ² × 10 ⁻⁴)
24VDC	A1□	0.0501 (0.00354)	0.069 (0.00487)	2	0.325	320	0.075	1.5072 (0.1064)
	A2□	0.0776 (0.00548)	0.0967 (0.00683)	2.6	0.65	221.5	0.108	2.4832 (0.164)

Speed / Torque Curves

24V Servomotors

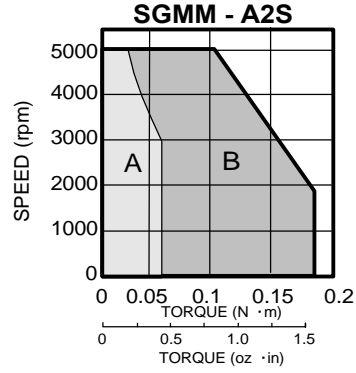
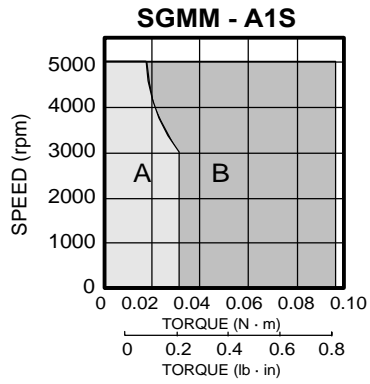

A : CONTINUOUS DUTY ZONE

B : INTERMITTENT DUTY ZONE

Dimensions in inches (mm)

(1) 2048PPR Incremental Encoder, without Brake

•10W (0.013hp), 20W (0.027hp)

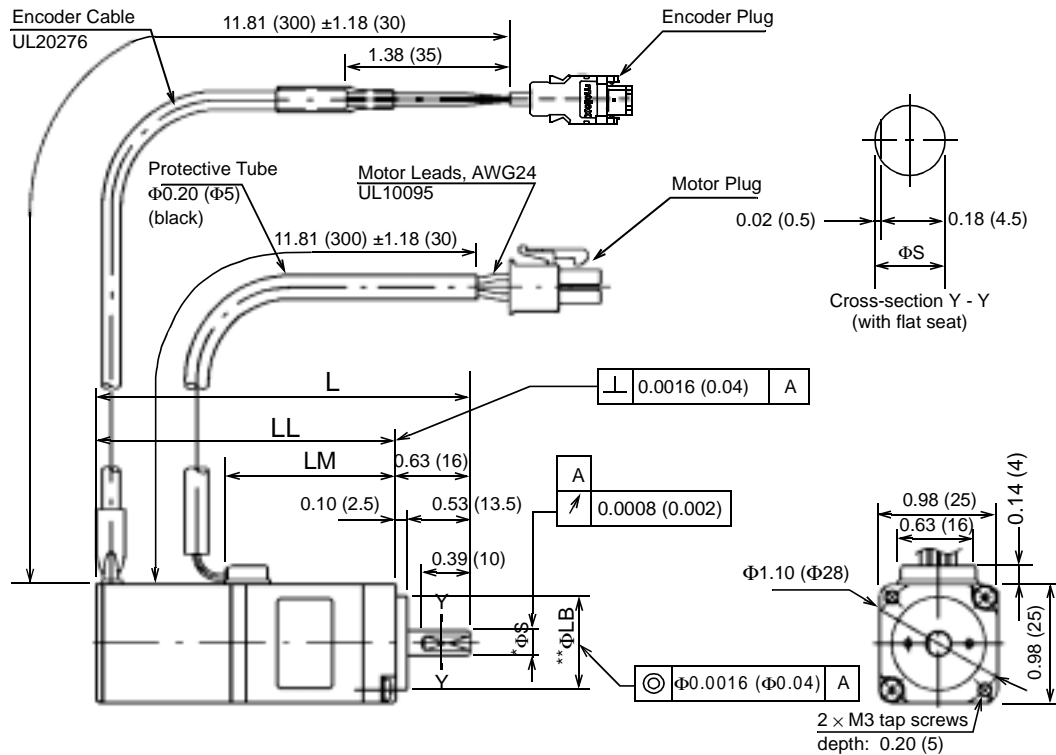

Type SGMM-		L	LL	LM	*ΦS	ΦLB	Output W (hp)	Approx Mass Oz (g)	Allowable Radial Load lb (N)	Allowable Thrust Load lb (N)
A1S312	Without Flat Seat	2.76	2.13	1.04	0.197	0.787	0.0133	4.23	7.7	3.3
A1S313	With Flat Seat	(70)	(54)	(26.5)						
A2S312	Without Flat Seat	3.15	2.52	1.44	(5)	(20)	0.0266	5.64	9.9	
A2S313	With Flat Seat	(80)	(64)	(36.5)						

Specified Tolerances		
	Diameter	Tolerance
*ΦS	0.197in	-0.0001 -0.0005
	5.000mm	+0.000 -0.008
**ΦLB	0.787in	+0.0004 -0.0001
	20mm	+0.000 -0.013

Note: The detector uses a 2048PPR incremental encoder.
The allowable load is applied to the shaft end.

Connector Specifications

Encoder Plug Plug 55101-0800 (Molex Japan)

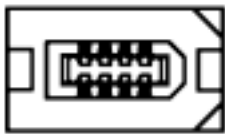

Connected to:
Socket: 54280-0600

Motor Plug



Receptacle: 5557-04R (Molex)
Terminal: 5556T

Connected to:
Socket: 5559-04P
Terminal: 5558T

Incremental Encoder Connection		
1	Channel A Output	Blue
2	Channel \bar{A} Output	Blue/Black
3	Channel B Output	Yellow
4	Channel \bar{B} Output	Yellow/Black
5	Channel C Output	Green
6	Channel \bar{C} Output	Green/Black
7	0V (Power Supply)	Grey
8	+5V (Power Supply)	Red
9	FG (Frame Ground)	Orange

Motor Connection		
1	Phase U	Red
2	Phase V	White
3	Phase W	Blue
4	FG (Frame Ground)	Green

(2) 2048PPR Incremental Encoder, with Brake

•10W (0.013hp), 20W (0.027hp)

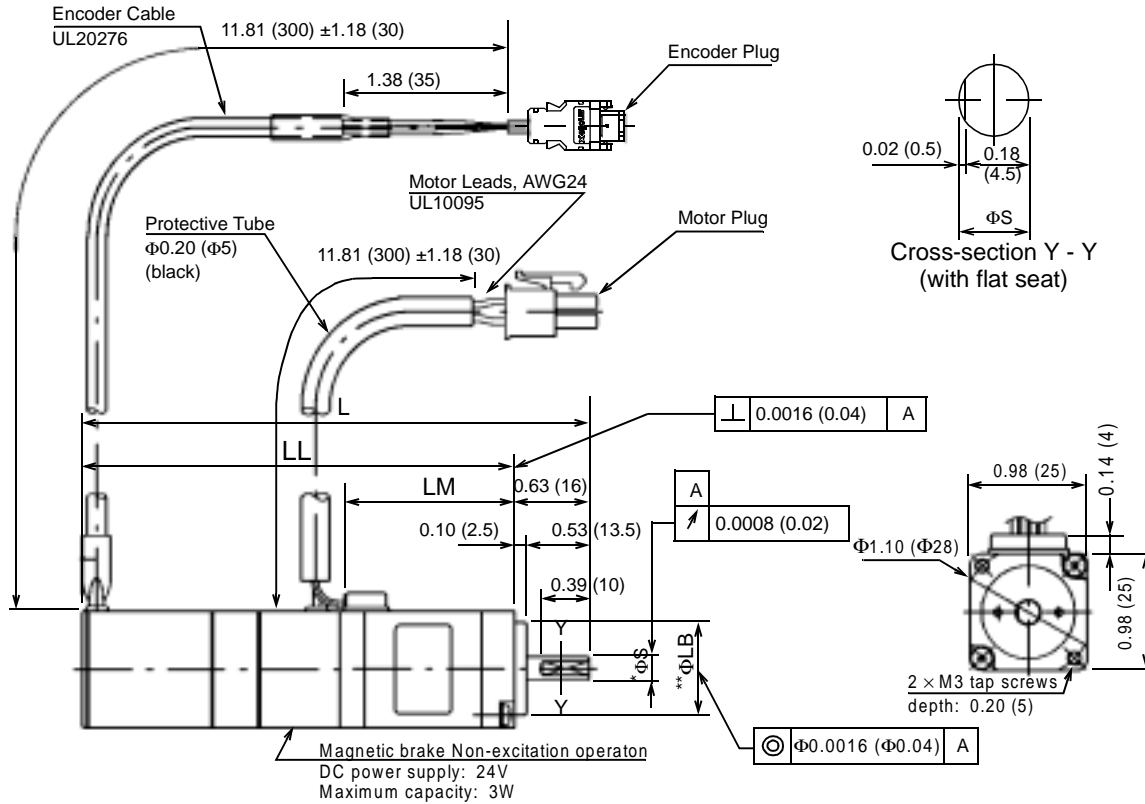

Type SGMM-	QK	L	LL	LM	*ΦS	ΦLB	Output W (hp)	Approx Mass Oz (g)	Allowable Radial Load lb (N)	Allowable Thrust Load lb (N)
A1S312C	Without Flat Seat	3.72	3.09	1.04	0.197	0.787	0.0133	7.23	7.7	3.3
A1S313C	With Flat Seat	(94.5)	(78.5)	(26.5)						
A2S312C	Without Flat Seat	4.27	3.64	1.44	(5)	(20)	0.0266	9.17	9.9	(14.7)
A2S313C	With Flat Seat	(108.5)	(92.5)	(36.5)						

Specified Tolerances		
	Diameter	Tolerance
*ΦS	0.197in	-0.0001 -0.0005
	5.000mm	+0.000 -0.008
**ΦLB	0.787in	+0.0004 -0.0001
	20mm	+0.000 -0.013

Note: The detector uses a 2048PPR incremental encoder.
The allowable load is applied to the shaft end.

Connector Specifications

Encoder Plug

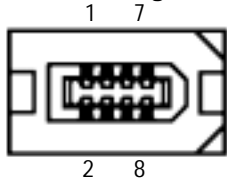

Plug 55101-0800 (Molex Japan)

Connected to:
Socket: 54280-0800

Motor Plug



Receptacle: 5557-06R (Molex)
Terminal: 5556T

Connected to:
Socket: 5559-06P
Terminal: 5558T

Incremental Encoder Connection		
1	Channel A Output	Blue
2	Channel \bar{A} Output	Blue/Black
3	Channel B Output	Yellow
4	Channel \bar{B} Output	Yellow/Black
5	Channel C Output	Green
6	Channel \bar{C} Output	Green/Black
7	0V (Power Supply)	Grey
8	+5V (Power Supply)	Red
9	FG (Frame Ground)	Orange

Motor Connection		
1	Phase U	Red
2	Phase V	White
3	Phase W	Blue
4	FG (Frame Ground)	Green
5	Brake Terminal	Black
6	Brake Terminal	Black

Selecting Your SGMM Sigma Mini Servo System

First, select the Sigma servomotor suited for your application using SigmaSize: the Yaskawa servomotor sizing software, available at no charge. (Request SigmaSize software via e-mail, at: literature@yaskawa.com).

Use the diagram below to locate and identify the components of your system. Each item is letter-coded and cross-referenced in the option tables on the following pages.

SGMM

System Configuration

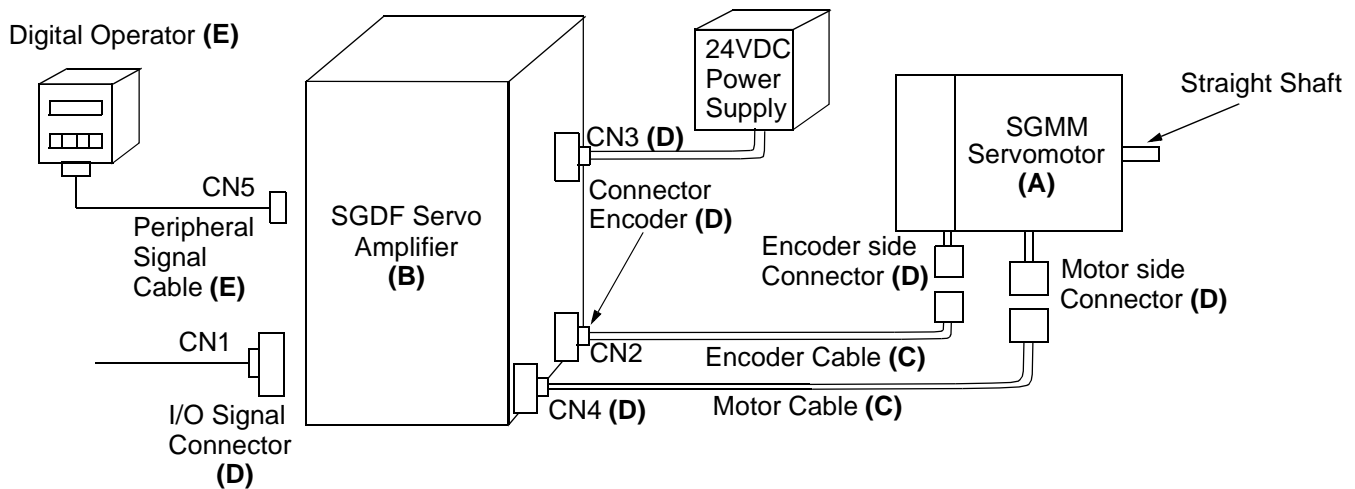

Model Number Designation

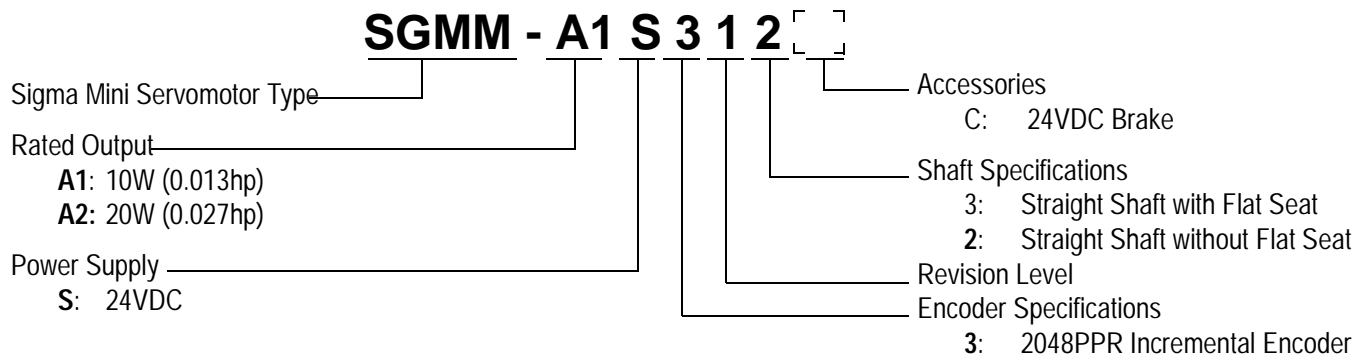

Note: Model number designations printed in boldface type represent stock items. Please contact Yaskawa for delivery on all other items. The model number designation is provided for reference only.

Servomotor & Amplifier Selection

Use the table below to select the recommended SGMM Sigma Mini Servomotor and Amplifier.





Motors Used with Incremental Encoders (3000rpm Rated Speed)					Amplifier		
Description	Peak Torque (oz. in.)	Rated Torque (oz. in.)	Motor Inertia (oz.in.s ² ×10 ⁻³)	Motor MODEL # (A)	Amplifier MODEL # (B)*		Motor & Amplifier Item Class
					Analog Input SGDF-	Digital Input SGDF-	
24VDC, 2048PPR Incremental Encoder Straight Shaft without Flat Seat	13.5	4.5	0.0501	SGMM-A1S312	A1CS	A1CP	Stock
			0.0690	SGMM-A1S312C			Limited Stock
	27.1	9.02	0.0776	SGMM-A2S312	A2CS	A2CP	Stock
			0.0968	SGMM-A2S312C			Limited Stock

Notes: 24VDC brakes for SGMM Sigma Mini servomotors are standard. Contact a local source for 24VDC power supplies. Motor power and encoder cables are factory pre-wired with approximately 12" lead length with amplifier mating connectors. Use the tables on the following pages to specify mating connectors or pre-wired cables available in various lengths. For technical information, request manual number SIE-S800-27 from your Yaskawa representative.

* For more detailed SGDF amplifier specifications and dimensions, refer to page 17.

Pre-wired Cable Selection

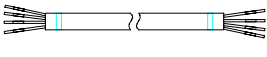
Use the table below to select Pre-wired Cables for your SGMM Sigma Mini Servomotor.

Cable Description (C)		Motor Size (W)	Part Number	Comments	Item Class	
Power Cable without brake		All	JZSP-CFM00-□(A)**	Use the following key to specify required cable length (last digit of part #): 01: 1m 03: 3m (standard) 05: 5m	Stock*	
Power Cable with brake			JZSP-CFM10-□(A)**			
Encoder Cable (incremental)			JZSP-VFP00-□(A)**			
Encoder Cable (for 5m maximum applications) Only for Solder Connections			DP8409123			For use with mating connector.
Input/Output CN1 Cable with Pigtail Leads			JZSP-VFI01-□(A)**			Use the following key to specify required cable length (last digit of part #): 01: 1m 03: 3m (standard)

* Standard cable lengths are Stock items; non-standard cable lengths are Limited Stock items.

** The "(A)" at the end of the cable part number indicates the revision level. Revision level may be subject to change prior to this catalog reprinting.





Connector Selection

Use the table below to select Mating Connectors or Kits for your SGMM Sigma Mini Servomotor.

Connector Description (D)		Motor Size (W)	Part Number	Comments	Item Class
Motor Power Mating Connector (without Brake)		All	JZSP-CFM9-2	These connector kits include pin and socket.	Stock
Motor Power Mating Connector (with Brake)			JZSP-CFM9-3		
CN4 Power Connector on servo amplifier side			JZSP-CFM9-1		
Motor Encoder Mating Connector			JZSP-VFP9-2	-	
CN1 I/O Connector			JZSP-VFP9	Connector for the amplifier side.	
CN2 Encoder Connector			JZSP-VFP9	Connector for the servo amplifier side.	
CN3 Power Connector			JZSP-CFG9	For 24VDC power supply.	

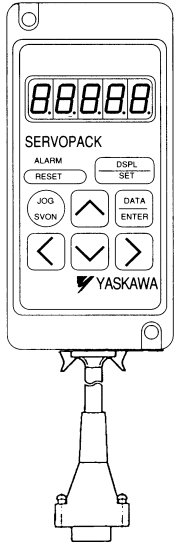
Peripheral Device Selection

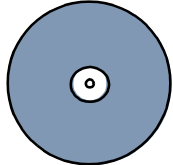
Use the table below to select Peripheral Devices for your SGMM Sigma Mini Servomotor.

Component Description (E)	Part Number	Comments	Item Class
<div data-bbox="0 430 73 619" style="writing-mode: vertical-rl; transform: rotate(180deg); background-color: black; color: white; padding: 5px; font-weight: bold;">SGMM</div> <p>Hand-held Digital Operator Panel</p>	 <p>JUSP-OP02A-1 + JZSP-CFS00</p>	<p>Portable unit with 1m cable for Sigma Mini</p>	<p>Stock</p>
<p>SVMON Software</p>	 <p>SVMON</p>	<p>Monitoring and configuration software for DOS 3.3 on a 3.5" floppy disk.</p>	
<p>Sigma Win™ Software</p>	 <p>SVWIN-F</p>	<p>Programming software for Windows 95, Windows 98, and Windows NT on a 3.5" floppy disk.</p>	<p>Stock</p>
	 <p>SVWIN-C</p>	<p>Programming software for Windows 95, Windows 98, and Windows NT on a CD-ROM.</p>	
<p>Software Interface Cable</p>	 <p>JZSP-CFS02-(A)</p>	<p>Pre-wired 2.0m cable with 9-pin connector</p>	<p>Stock</p>

SGDF Sigma Mini Servo Amplifier



For Additional Information	Page(s)
SGDF Ratings & Specifications	16 - 17
SGDF Dimensions	18
SGDF Internal Connections	19 - 22
Overload Characteristics	23
Cable Specifications and Peripheral Devices	24 - 26

Design Features

1. **Compact**
 - Small sized servo amplifier
Compatible with incremental encoder feedback.
2. **Quick Response (for Speed/Torque Control)**
 - Speed control range 1:5000
 - Frequency characteristics 250Hz
Positioning time is shortened.
3. **Easy Operation**
 - Includes auto-tuning function, JOG operation, various monitoring functions (I/O monitor, wave form display of speed and torque, and error messages) and PC monitoring function.
4. **Simple Wiring**
 - Simplified trouble-free wiring work
5. **Improved Environmental Resistance**
 - Shock resistance: 15G
 - Vibration resistance: 1G
6. **Electronic Gear Function is Built-In (for Position Control)**
 - Electrically converts encoder pulse numbers to “command unit equal to machine transitional units”.
 - Can change users’ pulse numbers to lower than 2048.
7. **Sinusoidal Commutation**
8. **Certified International Standards**
 - CE-compliance

SGDF

Model Number Designation

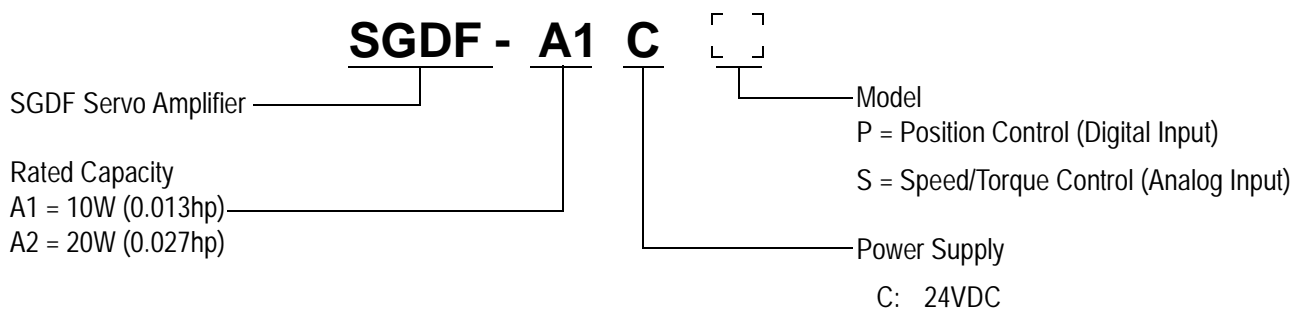

SGDF Amplifier Ratings and Specifications

Voltage	Servo Amplifier SGDF-	Maximum Applicable Motor Capacity W (hp)	Combined Specifications				Basic Specifications	
			Maximum Output Current A_{rms}	Rated Output Current A_{rms}	Motor		Type	Approx. Mass kg (lb)
					Allowable Load Inertia J_L oz · in · s ² × 10 ⁻³ (kg · m ² × 10 ⁻⁴)	Motor Capacity W (hp)		
24VDC	A1□	10 (0.013)	6.0	2.1	1.5072 (0.1064)	10 (0.013)	A1□	0.3 (0.66)
	A2□	20 (0.027)	5.7	2.0	2.3232 (0.164)	20 (0.027)	A2□	

SGDF Amplifier Ratings and Specifications

Basic Specifications	Power Supply		24VDC ±10%	
	Control Method		MOSFET-PWM	
	Feedback		Incremental encoder 2048PPR	
	Location	Ambient Temperature	0 to 50°C ¹	
		Storage Temperature	-20 to +85°C	
		Ambient/Storage Humidity	90% or less (with no-condensation)	
Vibration/Shock Resistance		1G/15G		
Structure		Base-mounted		
Performance (Speed/Torque Control)	Speed Control Range ²		1 : 5000	
	Speed ³ Regulation	Load Regulation	0% to 100%: 0.01% maximum (at rated speed)	
		Voltage Regulation	0%	
		Temperature Regulation	25 ± 25°C : 0.1% maximum (at rated speed)	
	Frequency Characteristics		250Hz (at J _L = J _M)	
	Torque Control (Repeatability)		± 2.0%	
Accel/Decel Time Setting		0 to 10s		
Input Signal (Speed/Torque Control)	Speed Reference	Rated Reference Voltage	±6VDC (forward motor rotation with positive reference) at rated speed (default setting) (variable setting range: ±2 to ±10VDC) at rated speed	
		Input Impedance	Approx. 30 kΩ	
		Circuit Time Constant	Approx. 47μs	
	Torque Reference	Rated Reference Voltage	±3VDC (forward motor rotation with positive reference) at rated torque (default setting) Variable setting range: ±1 to ±10VDC at rated torque	
		Input Impedance	Approx. 30 kΩ	
		Circuit Time Constant	Approx. 47μs	
Performance (Position Control)	Bias Setting		0 to 450rpm (Setting resolution: 1 rpm)	
	Feed Forward Compensation		0 to 100% (Setting resolution: 1%)	
	Position Complete Width Setting		0 to 250 reference units. Reference unit: Minimum unit of position data which moves load	
Input Signal (Position Control)	Reference Pulse	Type	SIGN + PULSE train, 90° phase difference, 2-phase pulse (A-phase + B phase), CCW pulse + CW pulse	
		Pulse Form	Line driver (+5V level), open collector (+5V or +12V level)	
		Pulse Frequency	0 to 450 kpps	
	Control Signal		CLEAR (input pulse form identical to reference pulse)	
I/O Signals	Position Output	Output Form	A-, B-, C-phase open collector output	
		Frequency Dividing Ratio	$\frac{\text{No.}}{N}$, where N = 2048 (the number of encoder pulses) Set the value of No. using a parameter.	
	Sequence Input (2 Outputs)		Servo ON, P drive (or motor forward/reverse by zero-clamp drive reference, or contact input speed control), current limit, alarm reset. Select using parameters.	
	Sequence Output (2 Outputs)		Current limit detection (or TGON), speed coincidence, external brake interlock, servo alarm	
Protective Functions		Overcurrent, overload, overspeed, overrun prevention, CPU error, encoder error, overflow		
Indicators		Red: Alarm; Green: Ready		
Others		Zero clamp operation (position loop stop), soft start/stop, speed coincidence, brake interlock signal output,, JOG run, auto-tuning		
Combined Specifications	Motor	Rated/Max. Motor Speed	3000/5000rpm	
		Applicable Encoder	Incremental encoder 2048PPR	

SGDF

- Notes: 1. The ambient temperature must be within the specified range. Even if the servo amplifier is installed in a box, the temperature inside the box must not exceed the range.
 2. The lowest speed of the speed control range is the point just before the motor stops under full-load condition.
 3. Speed regulation can be calculated using the following formula:

$$\left(\text{Speed regulation} = \frac{(\text{no-load motor speed} - \text{full-load motor speed})}{\text{rated motor speed}} \times 100\% \right)$$

Under actual operating conditions, voltage or temperature fluctuation causes drift to the amplifier or changes the operating resistance, resulting in the motor speed being changed. The percentage of the motor speed change to the rated motor speed is called "speed regulation."

Dimensions in inches (mm)

SGDF

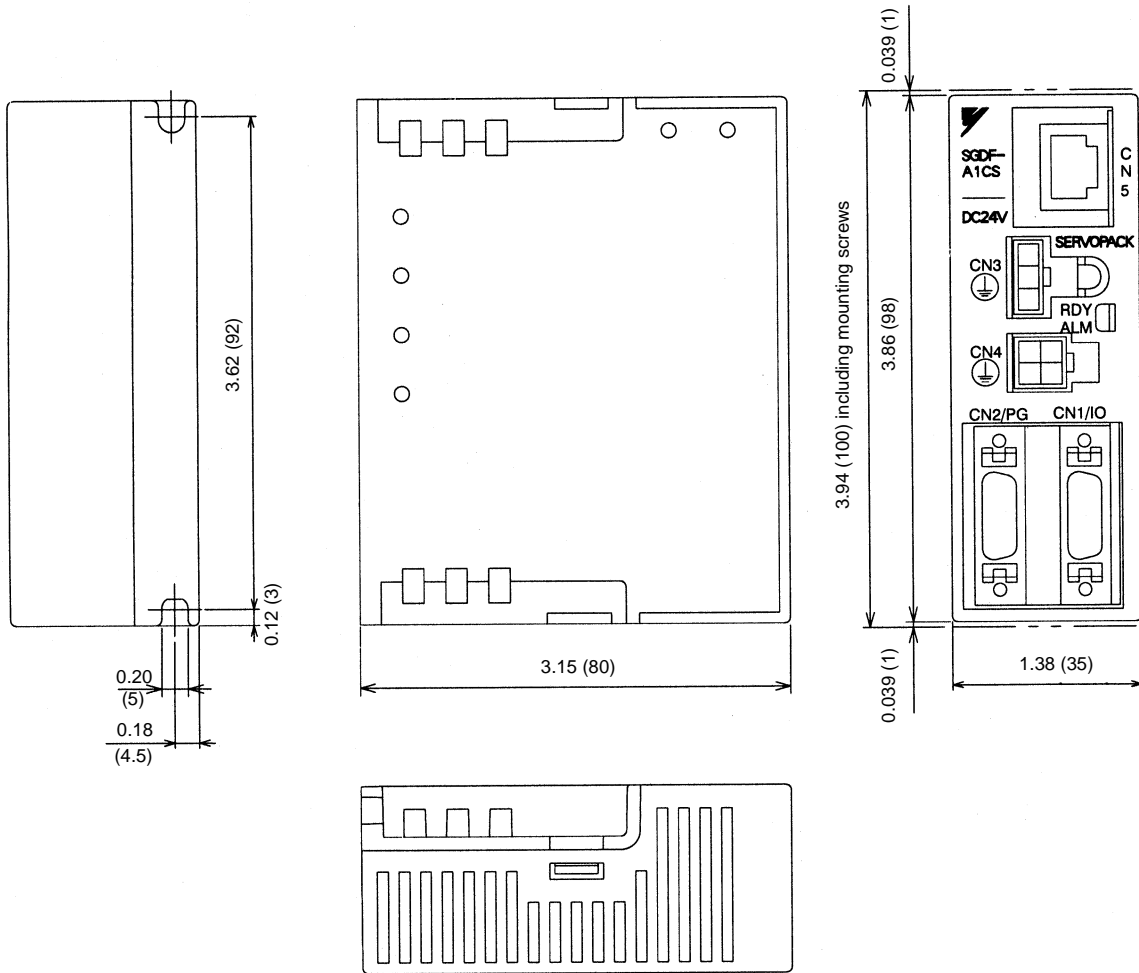

Approx. Mass 0.66lb (0.3kg)

Internal Connection Diagrams

• Internal Connections for Speed/Torque Control

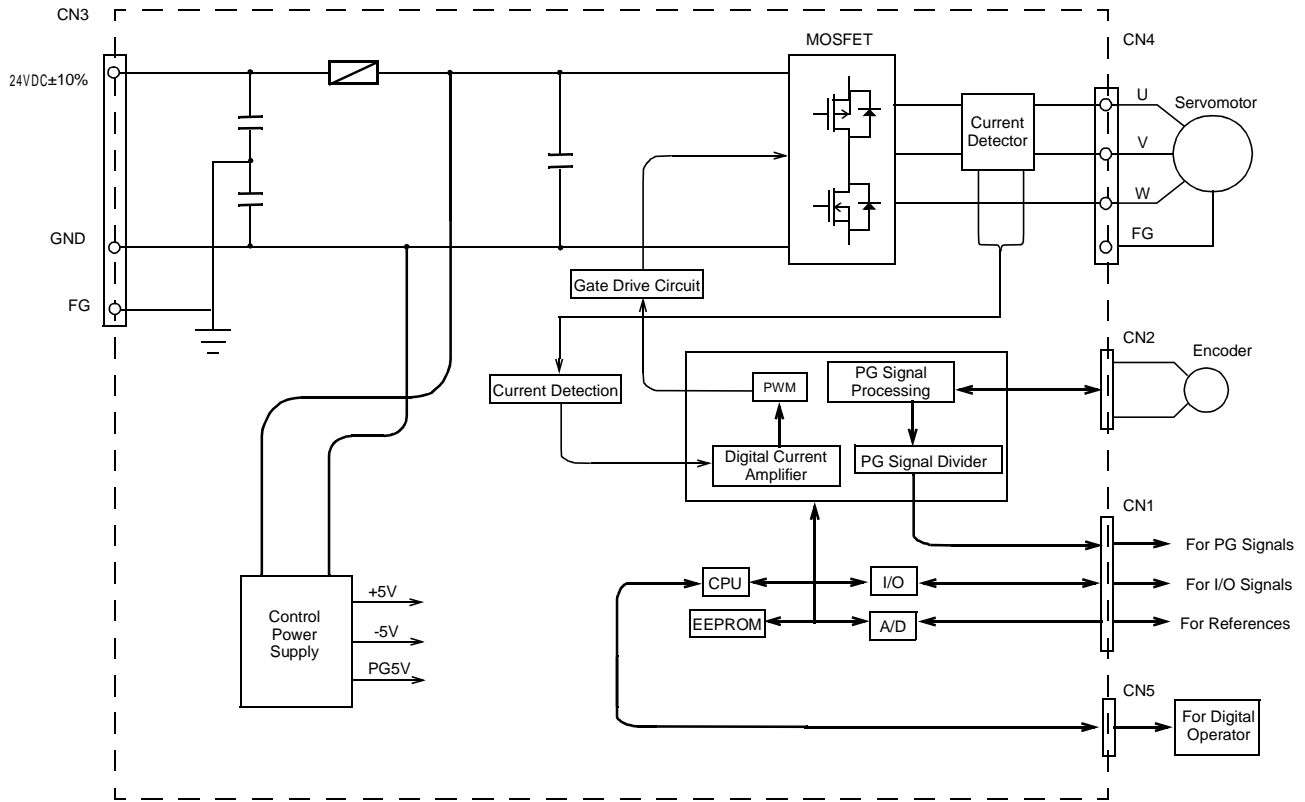

• Internal Connections for Position Control

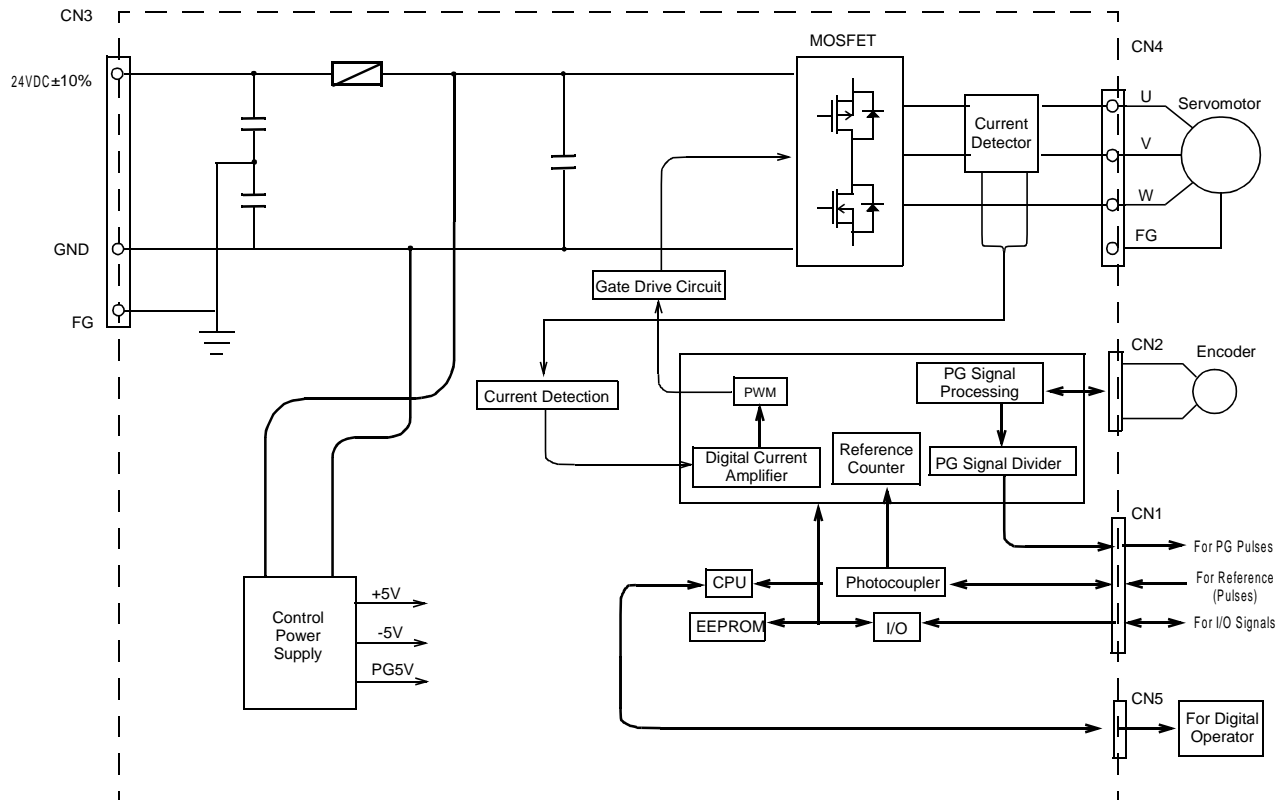

SGDF

Internal Connection Diagram

Encoder Signal (2CN) Connections

- Connector 2CN for Incremental Encoder Connection and 1CN Output Processing

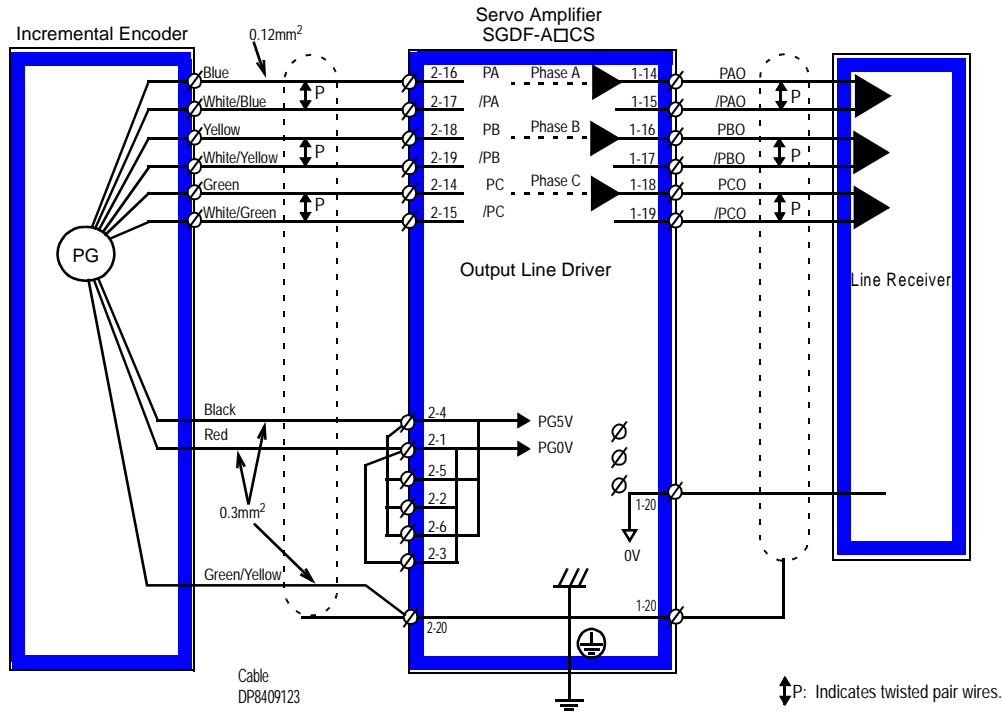

SGDF

Internal Connection Diagram

- Connection Example: SGDF servo amplifier (SGDF-□□CS), SGMM servomotor (with incremental encoder), and peripheral devices.

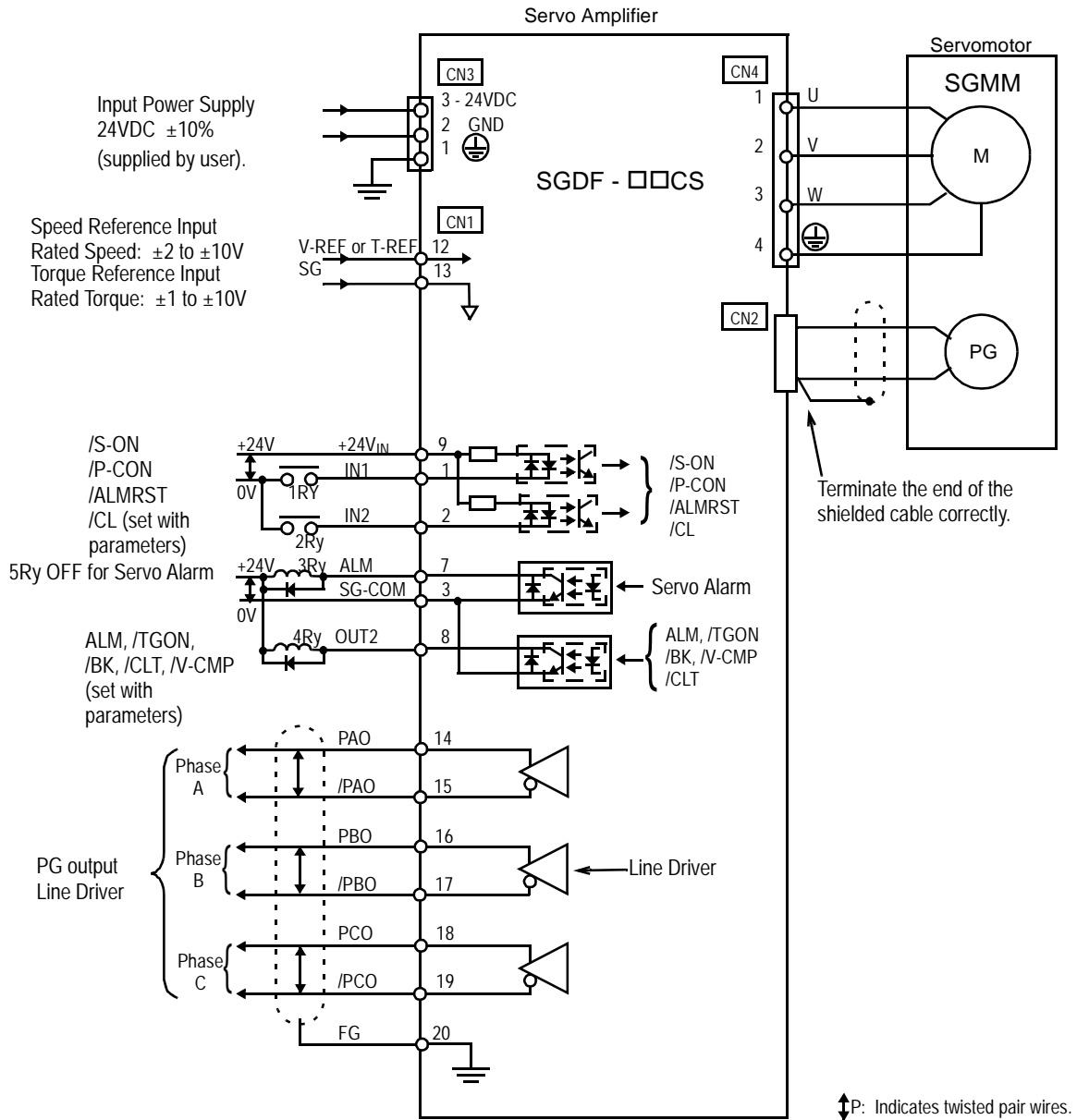

Note: The capacity of each output circuit is less than 30VDC and 50mA.

Internal Connection Diagram

- Connection Example: SGDF servo amplifier (SGDF-□□CP), SGMM servomotor (with incremental encoder), and peripheral devices.

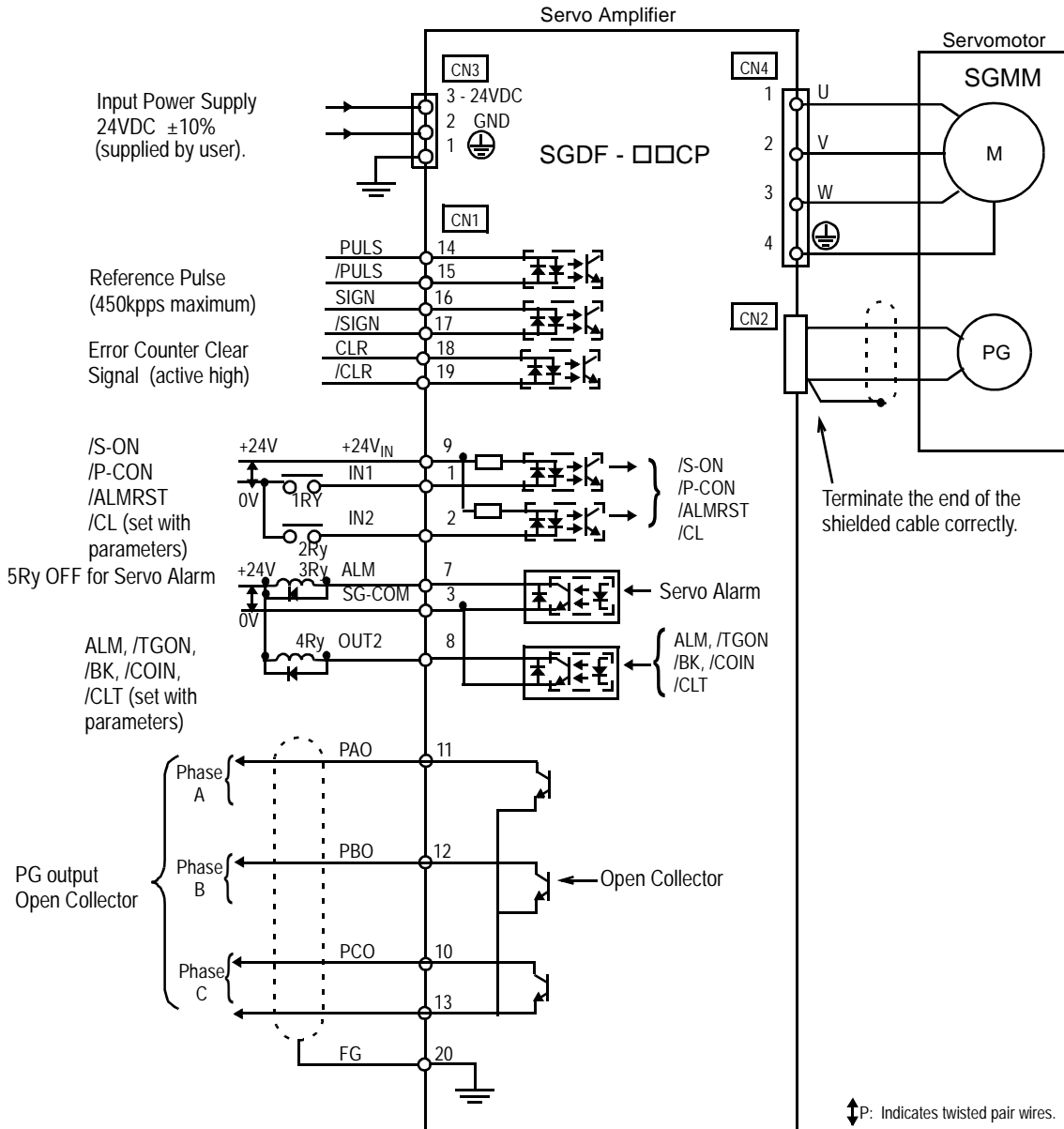

Note: The capacity of each output circuit is less than 30VDC and 50mA.

Overload Characteristics

Servo amplifiers have a built-in overload protection function that prevents overload of both servo amplifiers and servomotors. This function limits allowable power for the servo amplifiers, as shown in this figure.

The overload detection level is set under hot start conditions at a servomotor ambient temperature of 40°C.

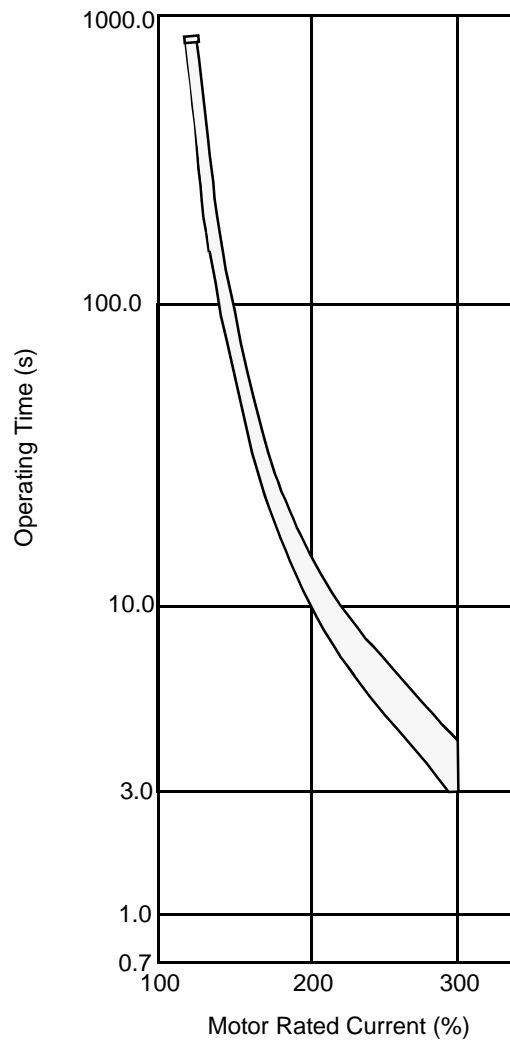

Cable Specifications and Peripheral Devices

Ratings and specifications for peripheral devices, as well as cable specifications for servo amplifiers are summarized in the tables below.

 <h2 style="margin: 0;">CAUTION</h2>
<ul style="list-style-type: none"> • Do not bundle or run power and signal lines together in the same duct. Keep power and signal lines at least 11.81" (30cm) apart. • Use twisted pair or shielded multi-core twisted pair wires for signal and encoder (PG) feedback lines. • The maximum lengths for signal lines are as follows: Maximum of 9.84ft (3m) for reference input lines. Maximum of 16.4ft (5m) for PG feedback lines.

Cable Specifications

The following table provides wire size specifications:

External Terminal Name		SGDF Terminal Symbol	Wire Size AWG [in ² (mm ²)]	
			A1C□	A2C□
for 24VDC	Main circuit power input terminals	CN3 pins No. 2, 3	20 AWG [HIV 0.0008 (0.5)]	
	Servomotor connection terminals	U, V, W		
	Ground terminal		12 AWG [HIV 0.005 (3.5)]	

- Notes: 1. Wire sizes were selected for three cables per bundle at 40°C ambient temperature with the rated current.
2. Use cables with a minimum withstand voltage of 60V for main circuits.
3. If cables are bundled in PVC or metal ducts, consider the reduction ratio of the allowable current.
4. Use heat-resistant cable under high ambient or panel temperatures where normal vinyl cable will rapidly deteriorate.

The following table shows types of cables. It is used in conjunction with the preceding tables.

Cable Type		Temperature Rating of Conductor °C
Name	Composition	
PVC	Standard polyvinyl chloride cable	—
—	Heat-resistant vinyl cable	80

The following table specifies the appropriate cables for CN1 and CN2 servo amplifier connectors.

Wire sizes were selected with the expectation of three cables per bundle, at an ambient temperature of 40°C, at the rated current level.

Connector Name	Signal	Description	Specification
I/O Signal Connector	CN1	Cable	Use twisted pair or shielded twisted pair wire.
		Applicable wire	28AWG
		Finished cable Dimension	Φ0.24in (Φ6.1mm) maximum
PG Signal Connector	CN2	Cable	Use Yaskawa cable, or shielded twisted pair wire.
		Applicable wire	Use 22 AWG [0.0005 in ² (0.34mm ²)] for the encoder power supply and 26 AWG [0.0002 in ² (0.14mm ²)] for other signals. These conditions permit wiring distances up to 16.4ft (5m).
		Finished cable Dimension	Φ0.3in (Φ7.5mm) maximum

Peripheral Device Types and Capacities

Main Circuit Power Supply	Model		Applicable Servomotor	Power Supply Capacity per Servo Amplifier (W)	MCCB or Fuse Capacity A*	Recommended Noise Filter		Magnetic Contactor
	Capacity (W)	SGDF-				Model	Specifications	
24VDC	10	A1C□	SGMM-A1S	27.6	5	MYB-1206-33 (Nemic-Lambda)	Single-phase 250VAC 6A	Contactor (30A) or equivalent
	20	A2C□	SGMM-A2S	40.1				

Note: *Operating characteristics at 25°C: 200% for 2s minimum; 700% for 0.01s minimum.

Peripheral Device Manufacturers

If the Nemic-Lambda noise filter is unavailable, please contact one of the other manufacturers to obtain a suitable substitute.

Nemic-Lambda:
 Lambda Electronics, Inc.
 515 Broad Hollow Road
 Melville, L.I., New York 11747-3700
 Phone: (516) 694-4200
 Fax: (516) 293-0519
 Internet: www.lambda.com

Schaeffner
 9b Fadem Rd.
 Springfield, New Jersey 07081
 Phone: (973) 379-7778
 (800) 367-5566
 Fax: (973) 379-1151

Okaya Electronic America
 503 Wall Street
 Valparaiso, Indiana 46383
 Phone: (800) 852-0122
 Fax: (219) 477-4856
 Internet: info@okaya.com

Tokin America, Inc.
 155 Nicholson Lane
 San Jose, California 95134
 Phone: (408) 432-8020
 Fax: (408) 432-0375
 Internet: www.tokin.com



Yaskawa . . . *A World of Automation Solutions*

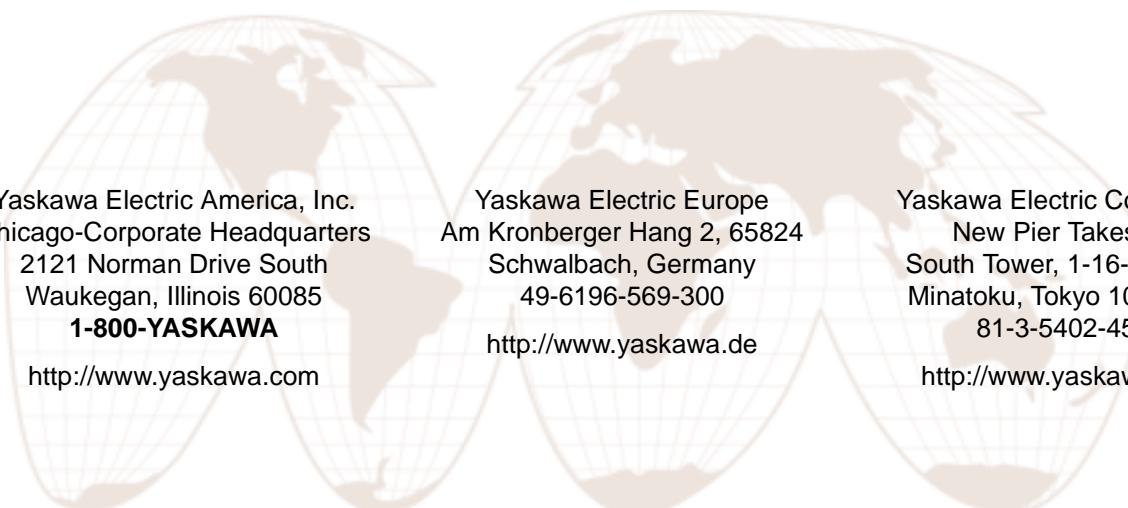

Yaskawa Electric America, Inc.
Chicago-Corporate Headquarters
2121 Norman Drive South
Waukegan, Illinois 60085
1-800-YASKAWA
<http://www.yaskawa.com>

Yaskawa Electric Europe
Am Kronberger Hang 2, 65824
Schwalbach, Germany
49-6196-569-300
<http://www.yaskawa.de>

Yaskawa Electric Corporation
New Pier Takeshiba
South Tower, 1-16-1 Kaigan
Minatoku, Tokyo 105 Japan
81-3-5402-4511
<http://www.yaskawa.co.jp>